

Instruction Manual
Model 7355
Curing Chamber
Revision E – September 2015
P/N: 07-1451

S/N: _____



2001 N. Indianwood Ave.
Broken Arrow, Oklahoma 74012 U.S.A.
Telephone: 918-250-7200
Fax: 918-459-0165
E-mail: chandler.sales@ametek.com
Website: <http://www.chandlereng.com>

Copyright © 2015, by Chandler Engineering Company L.L.C.

All rights reserved. Reproduction or use of contents in any manner is prohibited without express permission from Chandler Engineering Company L.L.C. While every precaution has been taken in the preparation of this manual, the publisher assumes no responsibility for errors or omissions. Neither is any liability assumed for damages resulting from the use of the information contained herein.

This publication contains the following trademarks and/or registered trademarks: AMETEK, CHANDLER ENGINEERING. These trademarks or registered trademarks and stylized logos are all owned by AMETEK, Inc. All other company, product and service names and logos are trademarks or service marks of their respective owners.

Table of Contents

General Information.....	P-1
Introduction	P-1
Purpose and Use	P-1
Description	P-1
Features and Benefits:.....	P-2
Safety Requirements	P-2
Specifications	P-2
Where to Find Help	P-3
Section 1 – Installation	1-1
Unpacking The Instrument.....	1-1
Utilities Required.....	1-1
Tools/Equipment Required	1-1
Setting Up the Instrument.....	1-2
Section 2 – Operating Instructions	2-1
Main Control Panel Functions.....	2-1
Pressure – Temperature Restriction Plate (1).....	2-1
Serial Number Plate (2).....	2-1
Nameplate (3)	2-1
Temperature Controller (4)	2-1
Pressure/Temperature Cut-off Reset (5)	2-2
Pressure Gauge (6).....	2-2
Air Supply Gauge (7)	2-2
Pump Switch (8)	2-2
Heater Switch (9).....	2-2
Power Switch (10)	2-2
High Pressure Regulator (11)	2-2
Pump Regulator (12).....	2-3
Thermocouple (13)	2-3
Water In Switch (14).....	2-3
Cooling Water Switch (15).....	2-3
Air Supply Switch (16).....	2-3
Air-To-Cylinder Valve (17).....	2-3
Pressure Release Valve (18)	2-3
Loading Cement Slurry.....	2-3
Closing the Cylinder Head	2-4
Program Temperature Controller	2-4
Pressurizing The Cylinder	2-4
Applying Heat to the Cylinder.....	2-5
High-Temperature Operation.....	2-5
Stop and Cool	2-6
Cooling of Cylinder	2-6
To Empty Cylinder of Water.....	2-6
High Pressure Safety Circuit.....	2-7

Strip Chart Recorder	2-7
Section 3 - Maintenance	3-1
Cleaning and Service Tips.....	3-1
Section 4 – Troubleshooting Guide	4-1
Section 5 - Replacement Parts	5-1
Model Number	5-1
Table 1 - Model 7355 Curing Chamber.....	5-1
Table 2 - Cylinder Assembly.....	5-2
Table 3 - 07-0386 Mold Assembly.....	5-2
Table 4 - Swivel Arm Assembly.....	5-2
Section 6 - Drawings and Schematics.....	6-1
 Additional Information	
4103CM Strip Chart Recorder	

General Information

Introduction

The Pressure Curing Chamber is used for curing tensile or compression specimens of oil well cements at elevated temperatures and at pressures above atmospheric, simulating conditions in the well.

The procedure is to prepare the test specimens according to API Spec.10¹. The specimen slurries are poured into molds, and the molds are lowered into the curing cylinder. The cylinder plug is installed, the thermocouple is inserted into the cylinder head, and the cylinder is filled with water to expel air.

The sample temperature is regulated by a temperature controller. Pressure is applied to the cylinder in accordance with applicable schedules of API Spec.10. Maximum pressure and temperature are maintained until shortly before the end of the curing time specified. The temperature is then reduced, pressure is reduced to atmospheric, and the test specimens are removed for testing.

Before a curing chamber leaves the factory, several tests are conducted to affirm that the assembly meets performance standards.

Purpose and Use

The Pressure Curing Chamber is used for curing tensile or compression specimens of oil well cements at elevated temperatures and pressures, simulating conditions in the well.

Description

The test specimens are prepared according to API Specification 10². The specimen slurries are poured into molds and the molds are lowered into the curing cylinder. The cylinder plug is installed, the thermocouple is inserted into the cylinder head, and the cylinder is filled with water to expel air.

A programmable temperature controller regulates the sample temperature. Pressure is applied to the cylinder in accordance with applicable schedules of API Specification 10. Maximum pressure and temperature are maintained until shortly before the end of the curing time specified. The temperature is then reduced, pressure is reduced to atmospheric, and the specimens are removed for testing.

Pressure relief is furnished by an adjustable relief valve through which water exhausts if pressure exceeds the set point. A rupture disc rated at 6275 psig (43 MPa) is also incorporated as a safety feature.

¹ American Petroleum Institute; API Specification 10 for Materials and Testing for Well cements, Latest Edition; Dallas, Texas

Features and Benefits:

- Programmable multi-slope temperature controller
- High wattage heater
- Stainless steel pressure vessel designed to meet ASME Section VIII – Div. 3 requirements
- Metal-to-metal sealing ring
- Operating temperatures to 700°F (371°C)
- Operating pressures to 34.6 MPa (5,000 psig)
- Internal cooling coils

Safety features are incorporated into the curing chamber. Adjustable switches are installed in the pressure gauge to shut off power to the heater if pressure falls below a selected point.

Over-pressure protection is furnished by a relief valve, through which water exhausts if pressure exceeds the set point. A rupture disc rated at 43 MPa (6275 psig) is incorporated as an additional safety feature.

Safety Requirements

READ BEFORE ATTEMPTING OPERATION OF INSTRUMENT!

Any instrument that is capable of the extremely high temperatures and pressures as a curing chamber should always be operated with **CAUTION**. The instrument is designed for operator safety; however, to ensure that safety:

- Locate the instrument in a **low traffic area**.
- Post signs where the instrument is being operated, to warn non-operating personnel.
- **Read** and **understand** instructions before attempting operation.
- Observe warning and caution notes throughout this manual.
- Observe and follow the **Warning Labels** on the instrument.
- **Never** exceed the instrument maximum pressure and temperature ratings secured on the machine.
- **Always** disconnect main power to the instrument before attempting any repair or when opening the instrument cabinet; **HIGH VOLTAGE CAN KILL!**
- Keep front access doors **closed** when operating instrument.
- A suitably rated fire extinguisher should be located within 50 feet of instrument.

Note: All Chandler Engineering™ equipment are calibrated and tested prior to shipment.

Specifications

Model No.	No. of Cubes	Maximum Temperature °F (°C)	Maximum Pressure Psig (MPa)	Power Requirement kVA	Shipping Weight lb (kg)	Shipping Dimensions, inches W x D x H
7355	16	700°F (370°C)	5000 (35)	8.5	1080 (491)	41 x 38 x 79

Where to Find Help

On site training classes are available. For more information, contact our sales department at Chandler Engineering. In the event of problems, your local sales representative will be able to help or you can contact the personnel at Chandler Engineering using the following:

- Telephone: 918-250-7200
- FAX: 918-459-0165
- E-mail: chandler.sales@ametek.com
- Website: www.chandlereng.com

Section 1 – Installation

Before the instrument is operated, the technician should study the drawings included in this operating and maintenance manual to become thoroughly familiar with the curing chamber operation and parts.

Hose or copper tubing may be used for the water supply connections to the curing chamber. All connections are located at the rear of the cabinet. The electrical cable (supplied with the instrument) must be connected to a mating receptacle having 40A breaker (supplied by customer). This unit is supplied with an installation kit, which includes the necessary hardware for the water, air, and electrical hook-ups.

Unpacking the Instrument

After the instrument is removed from the shipping crate, the operating equipment and spare parts on the packing list must be checked to affirm that all have been received and none are damaged.

Note: File an insurance claim with your freight carrier if damage has occurred during shipment. Verify all parts shown on the enclosed packing list have been received. If items are missing, please notify Chandler Engineering immediately.

Utilities Required

The utilities required to operate the typical instrument are compressed air at 100-125 psig and electric current of 200-240VAC, 50/60 Hz $\pm 10\%$, 40 ampere capacity. Water is used for cooling as well as the hydraulic medium.

*Note: The **Water Supply** valve must remain open during all testing and cooling operations. Water will flow continuously through the regulator heat exchanger to prevent damage to the high-pressure back-pressure regulator.*

Caution: Wiring should comply with local electrical codes. Pressure curing chamber should be securely connected to separate ground. The ground wire must have a larger diameter than that of the supply voltage conductors.

Warning: Water coming from cooling coils during high-temperature test vaporizes into steam. The outlet tube becomes hot. The correct outlet tube must be installed. A copper tube is recommended instead of hose connection. This outlet also must handle discharge in the event of blow-out disc rupture.

Tools/Equipment Required

A standard maintenance or mechanics tool set is adequate for the installation, operation, and maintenance of this instrument. No special tools are required.

Setting up the Instrument

1. Connect the utilities including water, air, drain and electrical to the curing chamber via the bulkhead ports at the rear of the instrument. The water drain hose must be properly secured because water coming from the cooling coils during high-temperature tests can vaporize into steam. This outlet also must handle discharge in the event of blow-out disc rupture.
2. Connect the communication cord from the curing chamber to the computer.

Section 2 – Operating Instructions

Main Control Panel Functions

Figure 1 below provides an illustration of the front control panel for the Model 7355 Curing Chamber. The function of each valve and switch is detailed following the figure.

Figure 1: Main Control Panel for Curing Chamber

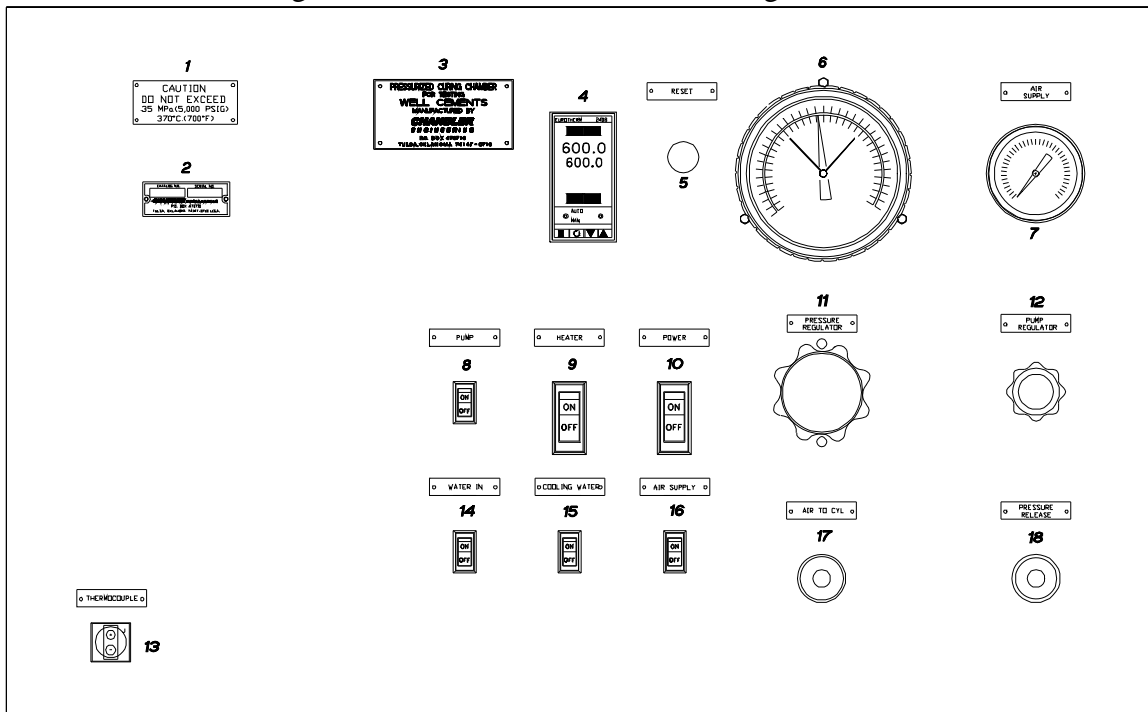

Pressure – Temperature Restriction Plate (1)

The PRESSURE – TEMPERATURE RESTRICTION PLATE indicates the working pressure and temperature limits of the instrument. Do not exceed these values during operation of the instrument.

Serial Number Plate (2)

The SERIAL NUMBER PLATE identifies the instrument. Both Model Number and Serial Number should be included when ordering spare parts to insure that the correct part is received.

Nameplate (3)

The NAMEPLATE denotes Chandler Engineering as the manufacturer and provides a descriptive name of the instrument.

Temperature Controller (4)

The TEMPERATURE CONTROLLER regulates the heater inside the curing chamber. The sample temperature is measured using the centerline thermocouple. Generally, the controller

is programmed to heat the sample to a stable temperature over a specified period of time and then dwell at that temperature.

For the heater to function the HEATER switch must be turned ON and the temperature controller must be operating. If a heat-up cycle must be stopped, switching the HEATER switch to the OFF position and pressing the RUN/HOLD button on the controller for 5 seconds can turn OFF the heater. Place the controller in Manual mode by pressing the Auto/Man button and verify that the Output Power is 0%.

Please see the Temperature Controller Operating Manual in the Components Section of this manual for detailed instructions on the operation of the temperature controller.

Pressure/Temperature Cut-off Reset (5)

The PRESSURE / TEMPERATURE CUT-OFF RESET is used to restore power to the curing chamber after an alarm condition has occurred. When the pressure exceeds the high or low pressure limits set on the gauge, the curing chamber heater and pump will shut-off.

Additionally, if the temperature exceeds 500°F (260°C) the curing chamber heater and pump will shut-off.

Pressure Gauge (6)

The PRESSURE GAUGE indicates the total system pressure. The pressure gauge is calibrated in units of PSIG and MPa. The Pressure Gauge has low and high pressure limits that must be set before a test is started. The pressure limits are set with the knobs on the front of the Pressure Gauge.

Air Supply Gauge (7)

The air supply pressure is monitored using the AIR SUPPLY GAUGE.

Pump Switch (8)

The PUMP SWITCH is used to turn the hydraulic pump on or off.

Heater Switch (9)

The HEATER SWITCH controls all of the power to the heater element. This switch will override any control to the heater by the temperature controller. The HEATER SWITCH must be in the ON position for the temperature controller to function.

Power Switch (10)

The POWER SWITCH controls all of the power to the unit.

High Pressure Regulator (11)

The HIGH PRESSURE REGULATOR is used to adjust the system pressure to the desired value.

Pump Regulator (12)

The PUMP REGULATOR is used to control the pressure of the hydraulic pump air supply. The supply pressure must be adjusted in accordance with the pressure desired inside the test cell.

Thermocouple (13)

The THERMOCOUPLE is the receptacle for the sample thermocouple. The sample thermocouple is connected at the beginning of each test.

Water In Switch (14)

The WATER IN SWITCH opens the water supply to the instrument allowing water to flow through the regulator and into the cylinder when filling it. This switch must always be in the ON position when running a test.

Cooling Water Switch (15)

The COOLING WATER SWITCH controls the supply of water to the cooling coils around the test cell. This switch does not affect the water supply, which flows through the regulator continuously when the instrument is operated at elevated temperatures.

Air Supply Switch (16)

The AIR SUPPLY SWITCH controls the air supply to the unit.

Air-To-Cylinder Valve (17)

The AIR-TO-CYLINDER VALVE is used to send air pressure to the top of the test cell to force the water out of the cylinder.

Warning: This valve must never be opened when the instrument is pressurized.

Pressure Release Valve (18)

The PRESSURE RELEASE VALVE is used to relieve pressure on the system.

Loading Cement Slurry

1. Prepare the cement slurry according to API Specification 10.
2. Load the slurry into the molds following API Specifications.
3. Lower the mold into the cylinder.

Closing the Cylinder Head







1. Before plug is lowered into cylinder, affirm that plug threads have been thoroughly lubricated with "Liqui-Moly" or similar high-temperature lubricant.
2. Lower plug into cylinder, and screw plug down firmly to ensure metal-to-metal seal.

Caution: Too rapid spinning of plug handles when seating plug will cause binding of metal-to-metal seal, and plug removal will be difficult. Final two turns of plug should be spun more slowly, following instructions in drawing 07-0749.

3. Tighten cylinder head per instructions on drawing 07-0749.
4. Thread thermocouple fitting part way into cylinder head. Delay tightening the thermocouple gland until cylinder is completely full and no air remains.
5. Press the switch, for the solenoid valve, to allow water to enter the cylinder and force air that's trapped in the cylinder out through the thermocouple gland. When water begins to flow past the gland, tighten the thermocouple fitting.

Program Temperature Controller

Program the temperature controller using the following instructions. For complete operating instructions, see the *7051 Operating Instructions* in the *Component* section of this manual.

1. Turn the controller on. Press  button until the Prog (Program) menu appears.
2. Press the scroll button until **seg.n** (segment number) is reached. Press  or  (UP/DOWN) button to change value to 1.
3. Press the  (scroll) button again until type (type) appears. This is the segment type.
4. Press  or  to change value to rmP.t
5. Scroll to tGt and change the value until the desired target is reached.
6. Scroll to dur and change the value until the desired duration is reached.
7. Scroll to Seg.n and change the value to 2.
8. Change the segment type to End.
9. Scroll to End.t and change the value to dwell.

The following procedure should be followed when operating the curing chamber:

Pressurizing The Cylinder

1. Turn the Air Supply Switch to ON.
2. Turn the Water In Switch to ON to allow water to enter the cylinder and force air that is trapped in the cylinder out through the thermocouple gland. When water begins to flow past the gland, tighten the thermocouple fitting.
3. Turn the Pump Switch ON.
4. Adjust air supply to the air-operated hydraulic pump by turning the Pump Regulator clockwise until desired hydraulic pressure is reached.

Caution: Using a pumping cycle that is too rapid can cause air lock in the pump piston cavity.

5. When the cylinder is pressurized to the desired limit and the pump slows down, adjust the High Pressure Regulator to maintain the upper limit of the pressure.

Note: The Water In Switch must remain in the ON position during all testing and cooling operations. Water will flow continuously through the regulator heat exchanger to prevent damage to the high-pressure regulator.

Applying Heat to the Cylinder

For complete operating instructions on the Temperature Controller, see the *7051 Operating Instructions* in the *Component* section of this manual.

Note: The chamber pressures will increase as the temperature increases. The High Pressure Regulator limits the pressure at the desired set point. The Upper and Lower Pressure Limits must be set on the Pressure Gauge before beginning a test.

To begin heating, use the following procedure:

1. Turn the Heater Switch ON.
2. Press the **Auto/Man** button to place controller in Auto mode.
3. Press the **Run/Hold** button to place in run.
4. Water in the "U" shape of the cooling coils from the previous test will vaporize during a high temperature test and give a water hammer effect. To eliminate, connect air supply to water inlet connection and blow all water from coils prior to starting test.

Caution: To avoid water hammer in cooling coils, connect air supply to water inlet connection and blow water from coils before beginning test. (Water remaining in U-shaped cooling coils will vaporize during high-temperature test and cause water hammer.)

High-Temperature Operation

The critical temperature of water is 705°F (374°C). At this temperature, the pressure is 3,205 psia (22.1 MPa).

Therefore, operation of the curing chamber at temperature above (or closely approaching) critical requires a special technique because the pressure medium is no longer a liquid, but a supercritical fluid. When operating above the critical point, water behaves similar to a gas and the pump may have difficulty increasing the pressure above 3,205 psia (22.1 MPa).

Caution: To avoid water hammer in cooling coils, connect air supply to water inlet connection and blow water from coils before beginning test. (Water remaining in U-shaped cooling coils will vaporize during high-temperature test and cause water hammer.)

*Note: The **Water Supply** valve must remain open during all testing and cooling operations. Water will flow continuously through the regulator heat exchanger to prevent damage to the high-pressure back-pressure regulator.*

Stop and Cool

1. Turn off the heater switch.
2. Press and hold **run/hold** button until run light is off.
3. Press the **auto/man** button to place controller in the manual mode.
4. Use $\sigma\tau$ buttons to change output value to “0.0%”.

Cooling of Cylinder

1. Depress the Cooling Water Valve switch to open valve, then turn switch to off position (open and close periodically).
2. Leave Pressure Bleed Valve closed and adjust pump to maintain pressure. Water will then be pumped into cylinder and improve cooling coil efficiency. Control pump at Regulator to limit amount of cold water contacting hot cylinder.
3. After temperature reaches 500°F (260°C) (saturated steam pressure 4.7 MPa), the standard cooling procedures can be followed.

Note: The internal cooling coils provide rapid cooling and rapid reductions of pressure due to thermal contraction. The pressure switch gauge should be set to 0, in order that the switch contact will not affect the true pressure reading and permit the air-operated hydraulic pump to operate.

4. When the cylinder and plug are cooled below 89°C (190°F), turn off pump, open the pressure bleed and water inlet valves by pressing switch to on position, and circulate water through cylinder for more rapid cooling.

Caution: Cool cylinder as long as API Spec 10 schedule permits. If water circulation is stopped prematurely, heat from the cylinder will cause a rise in temperature of water remaining in the cylinder, and the water can become hazardous steam.

*Note: The **Water Supply** valve must remain open during all testing and cooling operations. Water will flow continuously through the regulator heat exchanger to prevent damage to the high-pressure back-pressure regulator.*

To Empty Cylinder of Water

1. Turn off switch for the cooling water valve.
2. Open pressure bleed valve and turn off water inlet valve switch.
3. Open air-to-cylinder valve. After water has drained from the cylinder, as indicated by air coming out of the drain, close the air-to-cylinder valve.
4. Unscrew thermocouple gland on cylinder head and remove thermocouple.
5. Loosen the set screws on cylinder plug head.
6. Unscrew cylinder plug and lift plug from cylinder.
7. Attach "T" handle or eye bolt to molds and lift molds from cylinder using the electric winch.
8. Transfer molds to water bath according to *API Spec. 10*.

High Pressure Safety Circuit

The Curing Chamber is equipped with a safety circuit that disables the heater and pump when the pressure varies from pre-defined High/Low limits. The High/Low limits are set on the Pressure Gauge. When the safety circuit is enabled, power to the heater and pump are removed and the water is turned off.

Set the pressure gauge limits at $\pm 1,000$ psig above and below the desired operating pressure using the knobs on the pressure gauge. When equipment or controller malfunction occurs causing the pressure to vary outside of these limits, the instrument will be placed in a safe mode of operation.

To reset the safety circuit, press the Pressure / Temperature Cut-off Reset button.

Strip Chart Recorder

Check the date of manufacture, on the instrument serial number tag, and replace the batteries in the recorder each year on that date. The battery specification is: Panasonic BR2330, 3V, Lithium. Follow the instructions in the Model 4103C Chessell Recorder procedure located in the Components section of this manual for complete details on battery replacement. It is important to follow the directions given in order to prevent loss of the recorder configurations.

Section 3 – Maintenance

MODEL 7355 CURING CHAMBER MAINTENANCE SCHEDULE					
Component	Each Test	Monthly	3 Months	6 Months	Annually
Low pressure Filter			Replace		
Cylinder Pressure Release Valve					Replace
Cylinder	Clean and inspect				Replace
Air to Cylinder Valve					
Plug Seal	Clean and inspect				
Seal Ring	Replace				
Pump					Maintenance by qualified technician
Pressure gauge					● Calibration
Temp. Controller Thermocouple	Inspect	● Calibration			Calibration by qualified technician
Heaters					Test by qualified technician
Rupture Disk					Replace
7 Micron High Pressure Filter		Replace			
Back Pressure Regulator			Replace stem, seat and o-rings		
Strip Chart Recorder					Replace battery. Panasonic BR2330, 3V, Lithium.

This maintenance schedule applies to normal usage conditions of two tests per day. Detailed procedures for these operations are contained in your manual.

● Per API Spec Requirements
◆ Where Applicable

Cleaning and Service Tips

1. Before each test, cement and other foreign matter should be cleaned off the plug and cylinder threads, the threads should be wiped dry, and the threads and seal ring should be lubricated with high-temperature lubricant. The factory application of "Everlube" and the technician's application of lubricant before each test enable effortless cylinder-plug removal, even after most severe high-temperature testing.
2. The top and sealing surface of the seal ring (See cylinder assembly drawings) and mating surface of the cylinder plug should also be kept clean and lubricated to prevent metal galling.
3. If loose cement falls into the bottom of the cylinder, the waste should be removed immediately to prevent its being forced out through the Pressure Bleed Valve. This will erode the stem and seat shortening the valve life, and plug the connecting tubing.
4. The relief valve seat is a high-temperature plastic and may require replacement if damaged by foreign particles. The high-pressure filter in the relief valve inlet may occasionally require cleaning.
5. Add SAE 10 oil to the air lubricator on the air-operated pressure pump as required. (Avoid running the lubricator dry.) Occasionally, this lubricator should be checked to affirm that oil is being fed into the air inlet to the pump at a rate of three to five drops per minute when the pump is operating.
6. Sufficient coil length was allowed by the factory to permit several gasket installations before a new coil is required. If necessary, replacement gaskets can be installed on the cooling coils as follows:
 - Cut off tip end of coil immediately above brass ferrules.
 - Remove coil at open cylinder end. Install replacement gaskets. Use new ferrules at tip ends. Bend copper tubes connecting to ends of the shorter coil.

Strip Chart Recorder

Check the date of manufacture, on the instrument serial number tag, and replace the batteries in the recorder each year on that date. The battery specification is: Panasonic BR2330, 3V, Lithium. Follow the instructions in the Model 4103C Chessell Recorder procedure located in the Components section of this manual for complete details on battery replacement. It is important to follow the directions given in order to prevent loss of the recorder configurations.

Section 4 – Troubleshooting Guide

PROBLEM	CHECK THIS	DO THIS
No Power	Fuses Or Breakers	Reset Or Replace
Will Not Heat	Heater Switch Heater Fuse Temp. Controller	Turn On Replace Check Program
Won't Hold Pressure	Pressure Release Valve Air-Operated Release Valve Back-pressure regulator External Leak	Close Close, set supply pressure to 50 psig Verify operation at various pressures, if inoperable, replace internal seat Tighten Connections
Can't Release Pressure	Air-Operated Release Valve High Pressure Filter	Replace Clean Or Replace
Shut-Down Failure	Rupture Disc	Replace
Erratic Temperature	Thermocouple Socket or Plug Temperature Controller	Clean Setup
Will Not Pump	Air Supply Valve Regulator Pump Switch Temperature and Pressure above critical point	Open Turn Clock-Wise Turn On Cool below critical point
Won't Cool	Water Supply Cooling Water Valve	Connect Open
Cylinder Plug Leaking	Plug Loose Seal Dirty	Tighten Clean And Inspect

*Note: Special instructions for releasing pressure if the high pressure filter is plugged:
Disconnect the low-pressure tubing from the air-to-cylinder valve, slowly open air-to-cylinder valve to release pressure.*

Section 5 - Replacement Parts

Model Number

Table 1 - Model 7355 Curing Chamber

PART NUMBER	DESCRIPTION
07-0967	Filter, Oil
07-1436	Internal Cooling Coil Assembly
70-0023	Thermocouple Assembly
98-0314	Heat Exchanger Assembly
7051	Controller, Temperature
C07358	Filter, High Pressure
C08262	Relay, Solid State, 45A
C08466	Power Supply, 24 VDC
C08936	Regulator, 50-6000 psig
C09111	Needle Valve, 1/4T
C09324	Rupture Disc, 6275 Psig
C09684	Contact, Power
C09685	Heat Sink, Heater SSR
C09694	Varistor, 240V
C10008	Relay, Pressure Latching
C10566	Battery, 3V, Lithium
C11062	Circuit, High Temperature Shut-down
P-0284	Regulator, 5-125 PSI
P-0518	Hydraulic Lubricator
P-0586	Check Valve
P-0659	Air-Hydraulic Pump
P-0665	Fuse, 40 Amp
P-0741	Snubber Restrictor
P-1838	Gauge, Switch-type
P-2380	Receptacle, Thermocouple
P-2881	Switch, Rocker
P-3107	Solenoid Valve, 240V
P-3388	Switch, Circuit Breaker

Table 2 - Cylinder Assembly

PART NUMBER	DESCRIPTION
07-0389	Strap, Heater
07-0454	Gasket, Cooling Coil
07-0748	Nut, Cooling Coil
07-0772	Handle, Plug
07-0894	Shaft, Seal
07-0895	Ring, Seal
07-0903	Jacket, Insulation
07-1433	Adapter, Plug
07-1434	Adapter, Cylinder
07-1436	Coil, Cooling
08-0081	Thermocouple Assembly
19-0091	Nut, Lock
19-0109	Washer, Thrust
P-1189	Union, Tube 1/4in (Cooling Coil)
P-1349	Heater, Ring
P-1876	Heater, Half Band, 1750W (4 ea. Required)

Table 3 - 07-0386 Mold Assembly

PART NUMBER	DESCRIPTION
07-0386	Hanger Assembly, Mold
07-0722	Plate, Cover
07-0781	Bracket, Mounting
07-0792	Tube, Center
07-0845	Mold, High Temperature
P-2032	Screw, #10-32 x 5/8"L Socket Head

Table 4 - Swivel Arm Assembly

PART NUMBER	DESCRIPTION
07-0382	Swivel Arm
07-0908	Hand Wheel, Hoist
P-0654	Cable Assembly, Hoist
P-1918	Hoist Assembly

To ensure correct part replacement, always specify model and serial number of instrument when ordering or corresponding.

Section 6 - Drawings and Schematics

Drawing Number	Description
07-0355	Model 7355 Curing Chamber
07-0381	Assembly, Swivel Arm
07-0749	Modified Bridgeman Seal
07-0860	Assembly, Double Compression Mold
07-0902	Assembly, Cylinder
07-1438	Panel ID, Model 7355 Curing Chamber
07-1449	Diagram, Wiring
07-1454	Diagram, Tubing

REVISIONS				
ZONE	REV	DESCRIPTION	DATE	APPROVED
C	ECN 7756	NEW FACE, NO REMOTE	05/02/02	BD/TC

SPECIFICATIONS

1. MAXIMUM WORKING PRESSURE:
5,000 PSI (34.6 MPa), 700°F(370°C),
6,000 PSI (42 MPa) RELIEF VALVE
2. HEATER CAPACITY: 7500 WATTS.
3. STAINLESS STEEL CYLINDER AND TUBING.
CYLINDER ASSY MEETS ASME-DIV3 REQUIREMENTS
4. INSTRUMENT CONFORMS TO RECOMMENDED
PRACTICE FOR CURING CEMENT SPECIMENS
AT PRESSURES ABOVE ATMOSPHERIC PER
API 10B SCHEDULES.

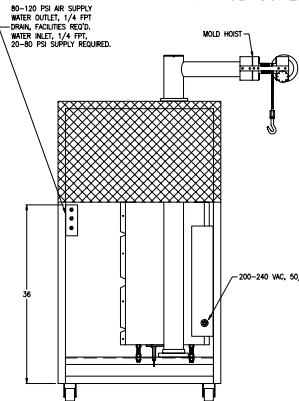
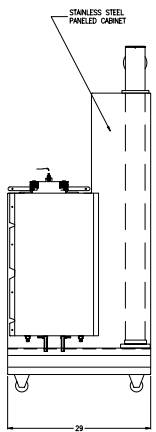
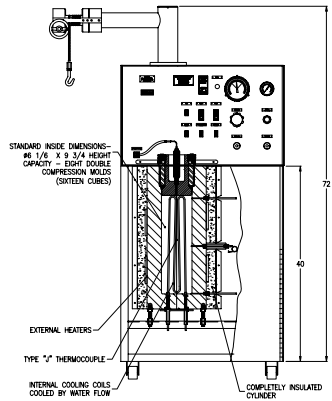
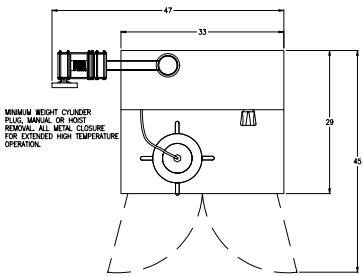

-04		-03		-02		-01		PART NUMBER		DESCRIPTION		MATERIAL SPEC.		ITEM	
QTY. REQD.								PARTS LIST							
								UNLESS OTHERWISE SPECIFIED DIMENSIONS IN INCHES (mm)							
								TOLERANCES:							
								1 PLACE +0.030 [-0.030]							
								2 PLACE +0.010 [-0.010]							
								3 PLACE +0.000 [-0.010]							
								ANGLES +1/2° ±1/2°							
								SURF. FINISH							
NEXT ASSY								USED ON							
APPLICATION								APPROVALS				DATE			
This document and the drawings and technical data contained herein are the property of Chandler Engineering Company LLC. Reproduction or dissemination in any form without the written authorization of the owner is prohibited. The holder agrees to return this document to the owner on demand.								DRAWN: <i>[Signature]</i>				03/01/01			
								CHECKED: <i>[Signature]</i>				02/20/02			
								ENGR.: <i>[Signature]</i>				03/01/01			
								SCALE: N/A				DO NOT SCALE DRAWING SHEET: 1 of 1			

CHANDLER ENGINEERING

MODEL 7355
CURING CHAMBER

SIZE: S.G. NO. DWG NO. REV. C
07-0355

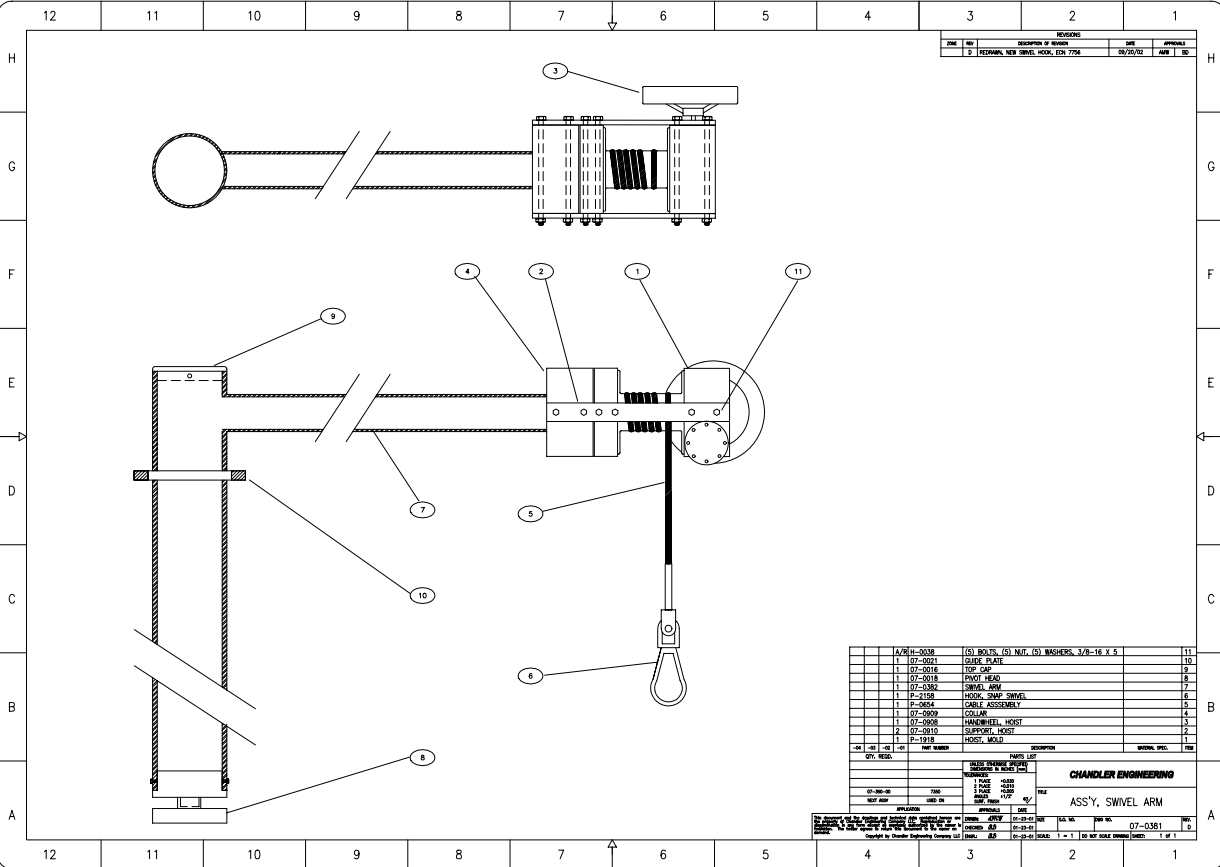

REVISIONS				
ZONE	REV	DESCRIPTION OF REVISION	DATE	APPROVAL
2		REPAIR, NEW SWIVEL HOOK, ECH 7756	08/20/02	AWB / SD

QTY	REQD.	REV	REV NUMBER	DESCRIPTION	SWIVEL, SWEL	REV
				(A) BOLTS, (C) NUT, (G) WASHERS, 3/8-16 X 5		11
				GUIDE PLATE		10
				TOP CAP		9
				PROT. HEAD		8
				SWIVEL ARM		7
				HOIST, SWIV. SWIVEL		6
				CABLE ASSEMBLY		5
				COLLAR		4
				HANDWHEEL, HOIST		3
				SUPPORT, HOIST		2
				HOIST, MOLD		1

MATERIALS		PARTS LIST	
07-300-02	TRD	REVISED	REVISED
REV. DATE	USED IN	DATE	DATE

CHANDLER ENGINEERING			
DATE	REV	DATE	REV
07-300-02	TRD	07-28-04	
07-300-02	TRD	07-28-04	
07-300-02	TRD	07-28-04	

ASSY, SWIVEL ARM

07-0361

6

5

4

3

2

1

REVISIONS				
ZONE	REV	DESCRIPTION	DATE	APPROVED
ALL	D	ECN 7100; CHANGED REV LETTER	01/24.01	AMW/BD

NOTES

- KEEP SEAL SURFACES CLEAN.
- TIGHTEN OPPOSING SET SCREWS TO 35 ft-lbs (47N-m) TORQUE PER SHEET 2 OF 2.
- ONLY CYLINDER PLUG SHOULD ROTATE WHEN SEAL RING CONTACTS CYLINDER TAPER.

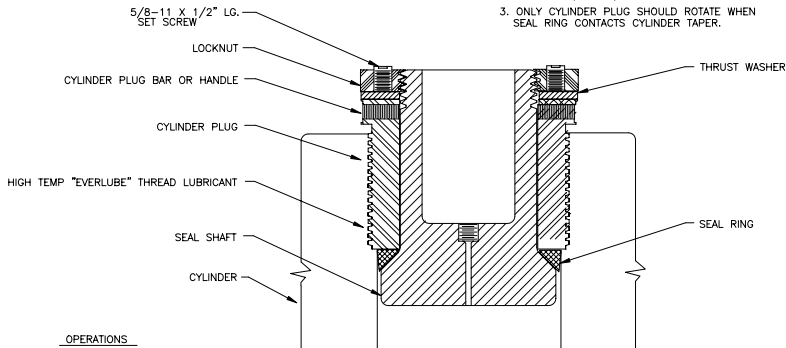

OPERATIONS

- THREADED PLUG IS SCREWED INTO CYLINDER UNTIL CONTACT IS MADE BETWEEN SEAL RING AND CYLINDER. BAR IS USED TO GENTLY TIGHTEN PLUG.
- SET SCREWS ARE TIGHTENED ACCORDING TO PATTERN SHOWN ON SHEET 2 OF 2, PULLING SEAL SHAFT AGAINST SEAL RING AND MAKING INITIAL SEAL.
- INTERNAL PRESSURE THEN FORMS A TIGHTER JOINT.

-04	-03	-02	-01	PART NUMBER	DESCRIPTION	MATERIAL SPEC.	ITEM
QTY. REQD.				PARTS LIST			
				UNLESS OTHERWISE SPECIFIED DIMENSIONS IN INCHES (mm)			
				TOLERANCES:			
				1 PLACE +0.030 [-.76]			
				2 PLACE +0.010 [-.25]			
				3 PLACE +0.005 [-.127]			
				ANGLES +1/2° 32/			
NEXT ASSY				USED ON			
APPLICATION				APPROVALS		DATE	
				DRAWN: <i>ABC</i>		01/27/99	
				CHECKED: <i>JH</i>		01/28/99	
				ENGR.: <i>PPM</i>		01/28/99	

CHANDLER ENGINEERING

MODIFIED BRIDGEMAN SEAL

This document and the drawings and technical data contained herein are the property of Chandler Engineering Company LLC. Reproduction or dissemination in any form except as expressly authorized by the owner is forbidden. The holder agrees to return this document to the owner on demand.

Copyright by Chandler Engineering Company LLC

SIZE	S.O. NO.	DWG NO.	REV. D
A3		07-0749	

SCALE: 1 = 1 DO NOT SCALE DRAWING SHEET: 1 of 2

6

5

4

3

2

1

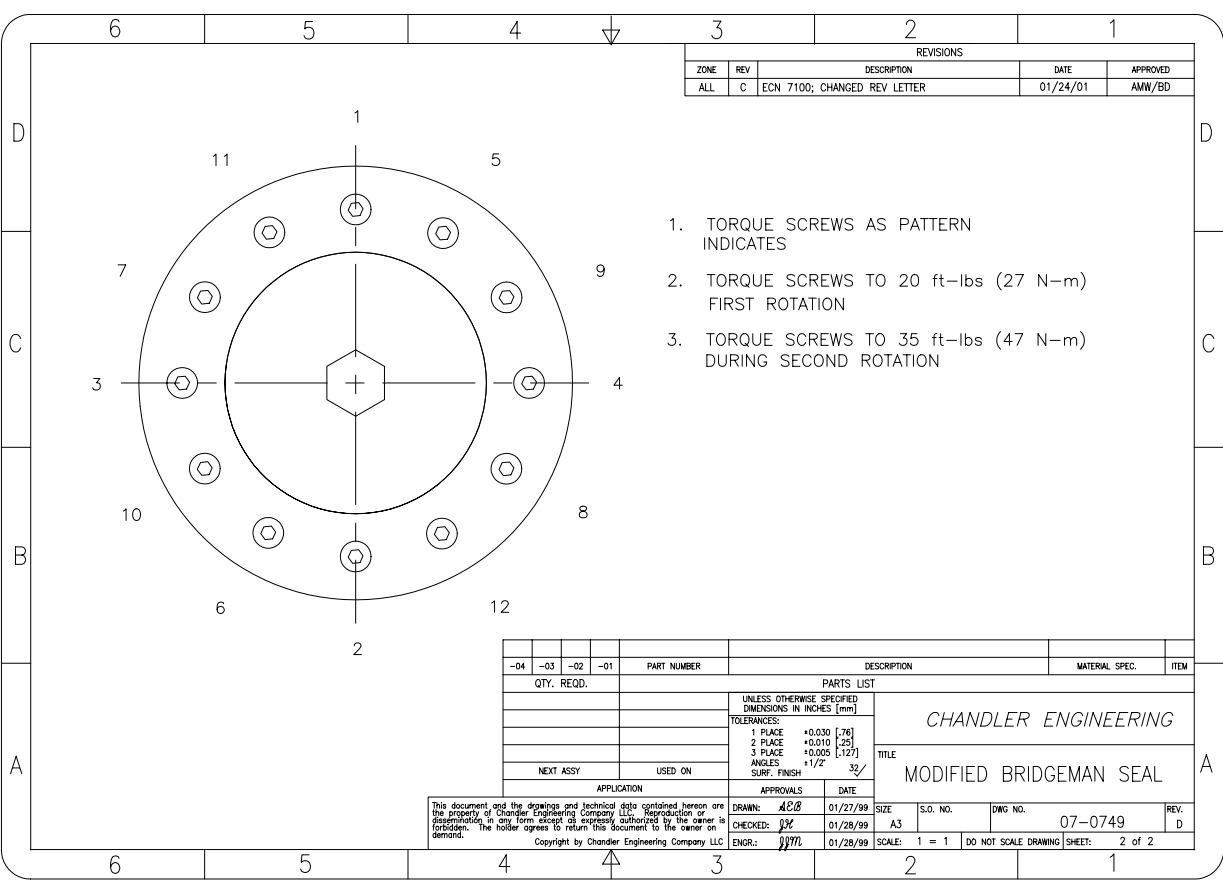

REVISIONS				
ZONE	REV	DESCRIPTION	DATE	APPROVED
ALL	C	ECN 7100; CHANGED REV LETTER	01/24/01	AMW/BD

1. TORQUE SCREWS AS PATTERN INDICATES
2. TORQUE SCREWS TO 20 ft-lbs (27 N-m) FIRST ROTATION
3. TORQUE SCREWS TO 35 ft-lbs (47 N-m) DURING SECOND ROTATION

-04	-03	-02	-01	PART NUMBER	DESCRIPTION	MATERIAL SPEC.	ITEM
QTY. REQD.				PARTS LIST			
				UNLESS OTHERWISE SPECIFIED DIMENSIONS IN INCHES (mm)			
				TOLERANCES:			
				1 PLACE +0.030 [-.76]			
				2 PLACE +0.010 [-.25]			
				3 PLACE +0.005 [-.127]			
				ANGLES +1/2° 32/			
				SURF. FINISH			
NEXT ASSY				USED ON			
APPLICATION				APPROVALS		DATE	
<small>This document and the drawings and technical data contained hereon are the property of Chandler Engineering Company LLC. Reproduction or dissemination in any form except as expressly authorized by the owner is forbidden. The holder agrees to return this document to the owner on demand.</small>				DRAWN: <i>ALB</i> 01/27/99 CHECKED: <i>[Signature]</i> 01/28/99 ENGR.: <i>[Signature]</i> 01/28/99		SIZE: A3 S.O. NO. DWG NO. 07-0749 REV. D	
Copyright by Chandler Engineering Company LLC				SCALE: 1 = 1		DO NOT SCALE DRAWING SHEET: 2 of 2	

CHANDLER ENGINEERING

MODIFIED BRIDGEMAN SEAL

REVISIONS				
ZONE	REV.	DESCRIPTION	DATE	APPROVED
	G	ECN T3327: H-37-003 WAS H-37-102	9/21/10	TC

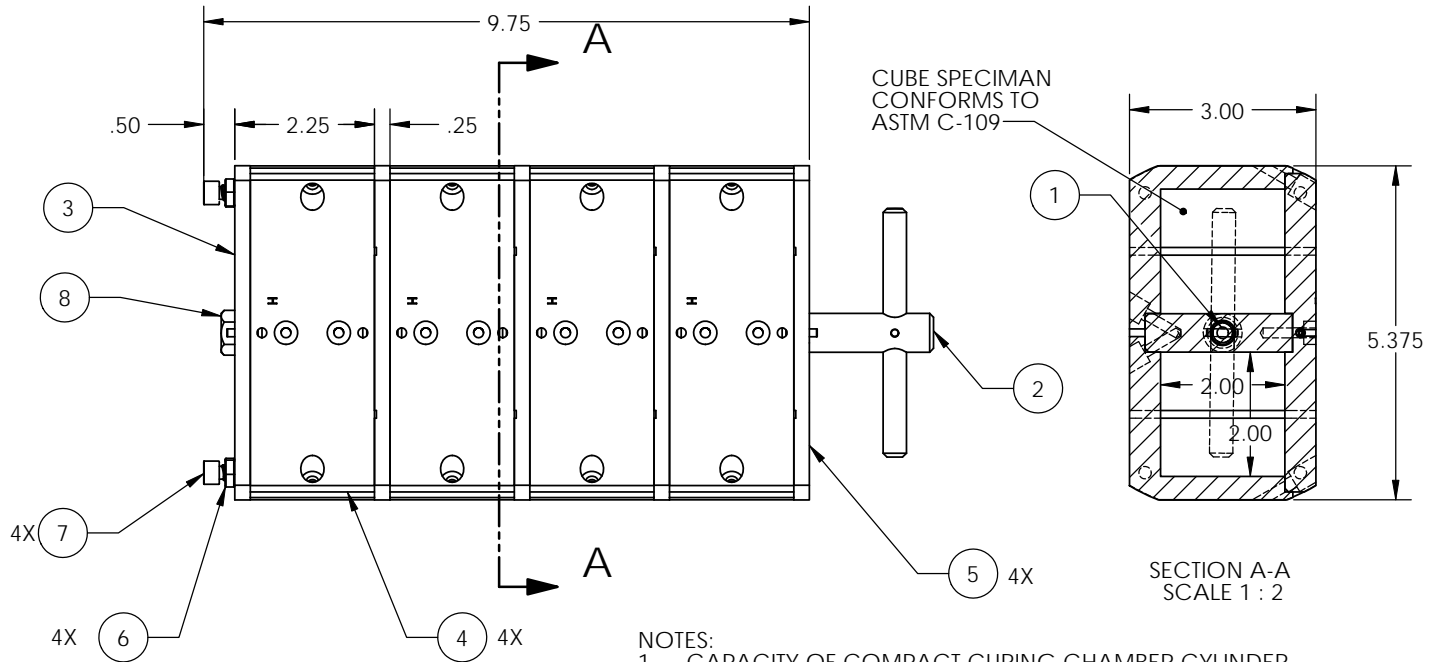

NOTES:
 1. CAPACITY OF COMPACT CURING CHAMBER CYLINDER
 4 DOUBLE COMPRESSION MOLDS (8 CUBES) (SHOWN)
 8 DOUBLE COMPRESSION MOLDS (16 DUMBELLS) OR
 ANY COMBINATION NOT EXCEEDING A STACKED HEIGHT
 OF 11 1/8"

ITEM NO.	PART NUMBER	DESCRIPTION	QTY.
1	07-0797	CENTER TUBE	1
2	07-0796	HANDLE, T	1
3	07-0882	PLATE, BOTTOM	1
4	07-0845	ASSEMBLY, MOLD	4
5	07-0886	PLATE, COVER	4
6	H-25-002	NUT, SST, HX, 10-32	4
7	H-25-010	SCREW, SHCS, SS, 1/4-20X0.500, ALN	4
8	H-37-003	NUT, HEX, SS, 3/8-16	1

NEXT ASSY		USED ON		UNLESS OTHERWISE SPECIFIED DIMENSIONS IN INCHES	
APPLICATION		BREAK SHARP EDGES, DEBURR		TOLERANCES:	
				1 PLACE ±0.030	
				2 PLACE ±0.010	
				3 PLACE ±0.005	
				ANGLES ±1/2°	
				SURF. FINISH 63/	
APPROVALS		DATE			
DRAWN: TC		8/31/07			
CHECKED: TC		8/31/07			
ENGR.: JJM		8/31/07			

CHANDLER ENGINEERING

TITLE: **MOLD ASSEMBLY**

SIZE: **B** S.O. NO. DWG NO. **07-0860** REV. **G**

SCALE: 1:4 TITLE BLOCK REV: 1.0 SHEET: 1 of 1

THIS DOCUMENT AND THE DRAWINGS AND TECHNICAL DATA CONTAINED HEREON ARE THE PROPERTY OF CHANDLER ENGINEERING COMPANY, L.L.C. REPRODUCTION OR DISSEMINATION IN ANY FORM EXCEPT AS EXPRESSLY AUTHORIZED BY THE OWNER IS FORBIDDEN. THE HOLDER AGREES TO RETURN THIS DOCUMENT TO THE OWNER ON DEMAND.
 COPYRIGHT BY CHANDLER ENGINEERING COMPANY, L.L.C.

REVISIONS				
ZONE	REV.	DESCRIPTION	DATE	APPROVED
	C	ECN T1113: UPDATE BOM, ADD NOTES	8/30/07	TC/JM
	D	ECN # 13145, UPDATE AND ADD PED CONTROLL	7/15/10	SS/TC

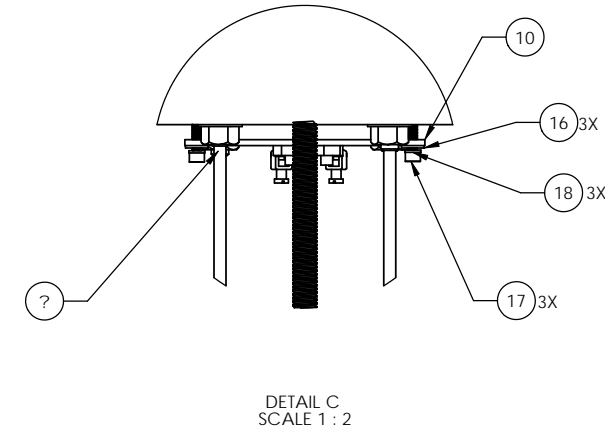
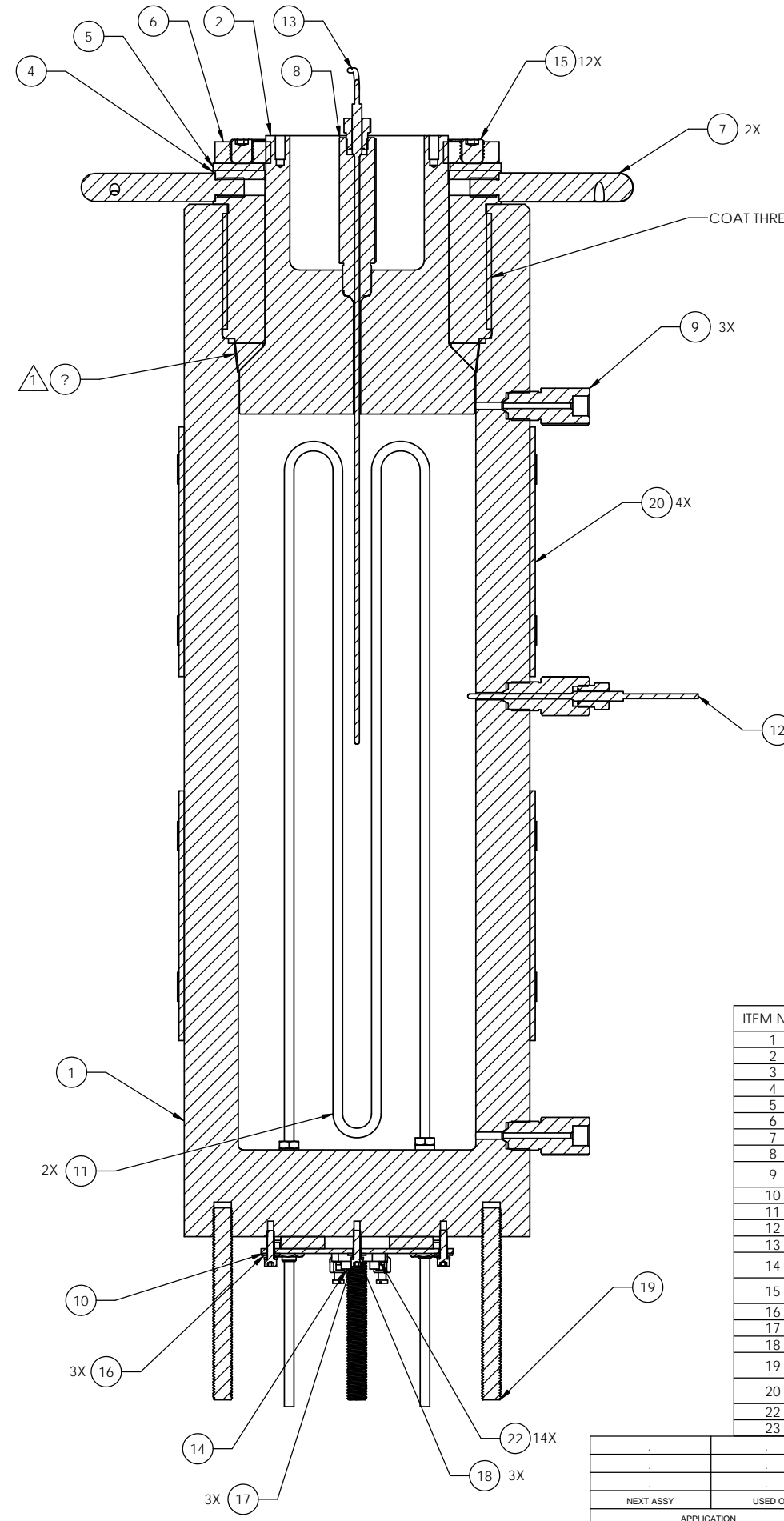
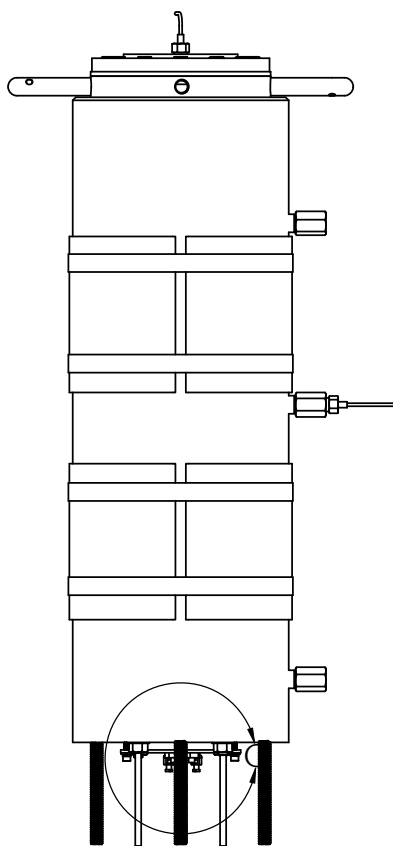
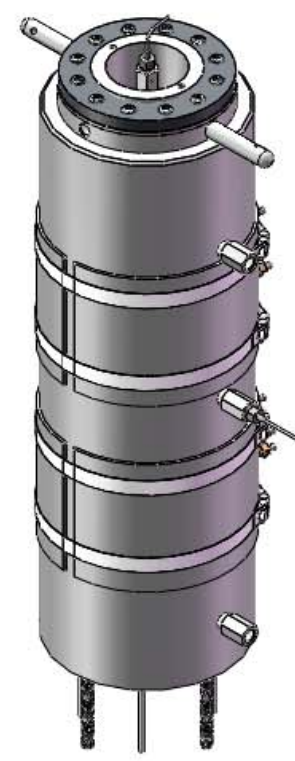
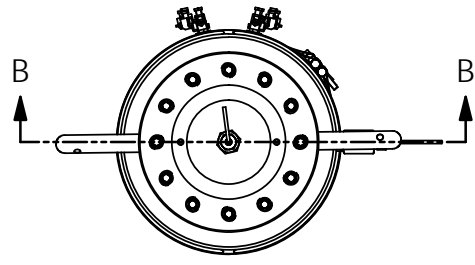
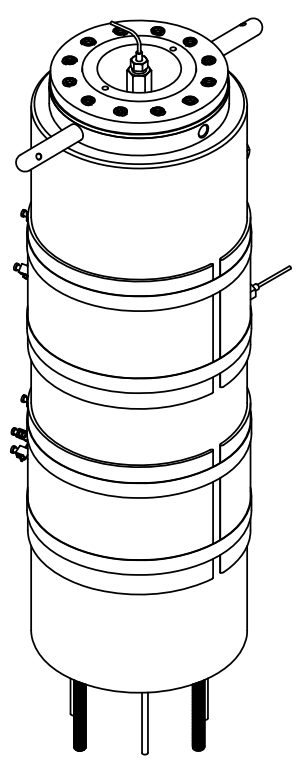

NOTES:
 1. COAT WITH C12056, SUPER SILVER SEALANT.
 2. TORQUE ITEM 8 PER 19-0107.
 3. TEST PER 07-1349.

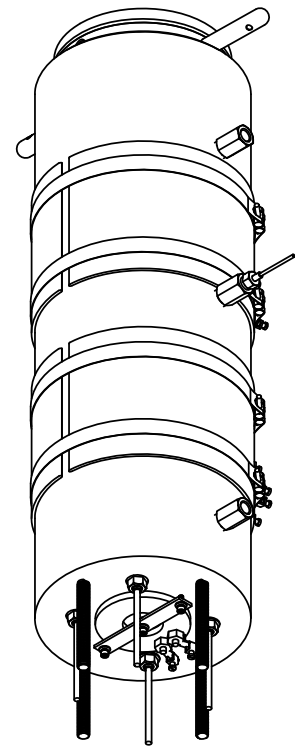
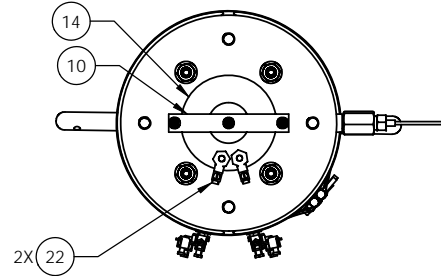
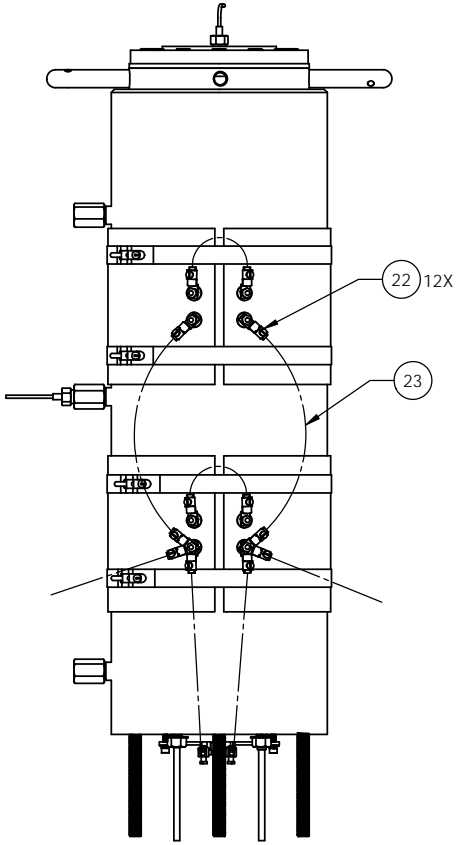

ITEM NO.	PART NUMBER	DESCRIPTION	Default/ QTY.
1	07-0892	CYLINDER	1
2	07-0894	SEAL SHAFT	1
3	07-0895	SEAL RING	1
4	07-0893	PLUG	1
5	19-0109	WASHER, THRUST	1
6	19-0091	NUT, LOCKING, HIGH TEMP	1
7	07-0772	HANDLE, PLUG	2
8	07-1448	ADAPTER, THERMOCOUPLE	1
9	07-1434	ADAPTER, WALL, THERMOCOUPLE	3
10	07-0389	HEATER STRAP	1
11	07-1436	COIL ASSY, INTERNAL COOLING	2
12	08-0081	THERMOCOUPLE	1
13	70-0023	THERMOCOUPLE	1
14	P-1349	HEATER, RING, 500W, 240V, 4.0 DIA	1
15	P-1792	SCREW, SKHSS, 5/8-11 X 5/8 LG, FLAT	12
16	H-10-003	WASHER, FLAT, SS, #10	3
17	H-10-125	SCREW, SHCS, SS, 10-32 X 3/4	3
18	H-10-002	WASHER, LOCK, SS, #10	3
19	R-0679	ST, ALL THREAD, 1/2-13, CR	2.09'
20	P-1876	HEATER, HALF CR, 1750W, 120V, 9 X 6.5	4
22	P-2031	LUG, #14-#6 CABLE, #10 STUD	14
23	R-0766	WIRE, 8 AWG, MICA TYPE	3'

UNLESS OTHERWISE SPECIFIED DIMENSIONS IN INCHES	
TOLERANCES:	
1 PLACE	±0.030
2 PLACE	±0.010
3 PLACE	±0.005
ANGLES	±1/2°
SURF. FINISH	SM
APPLICATION	
BREAK SHARP EDGES, DEBURR	
APPROVALS	DATE
DRAWN: TC	8/30/07
CHECKED: JM	9/4/07
ENGR.: JJM	8/30/07

CHANDLER ENGINEERING
 TITLE: CYLINDER ASSY, 7355

THIS DOCUMENT AND THE DRAWINGS AND TECHNICAL DATA CONTAINED HEREON ARE THE PROPERTY OF CHANDLER ENGINEERING COMPANY, L.L.C. REPRODUCTION OR DISSEMINATION IN ANY FORM EXCEPT AS EXPRESSLY AUTHORIZED BY THE OWNER IS FORBIDDEN. THE HOLDER AGREES TO RETURN THIS DOCUMENT TO THE OWNER ON DEMAND. COPYRIGHT BY CHANDLER ENGINEERING COMPANY LLC.		DWG NO. 07-0902	REV. D	SCALE: 1:8	TITLE BLOCK REV: 1.0	SHEET: 1 OF 2
--	--	-----------------	--------	------------	----------------------	---------------

PED CONTROLLED DRAWING

6

5

4

3

2

1

REVISIONS				
ZONE	REV	DESCRIPTION	DATE	APPROVED
	C	ECN 7756, NEW FACE, NO REMOTE	05/03/02	BD/TC

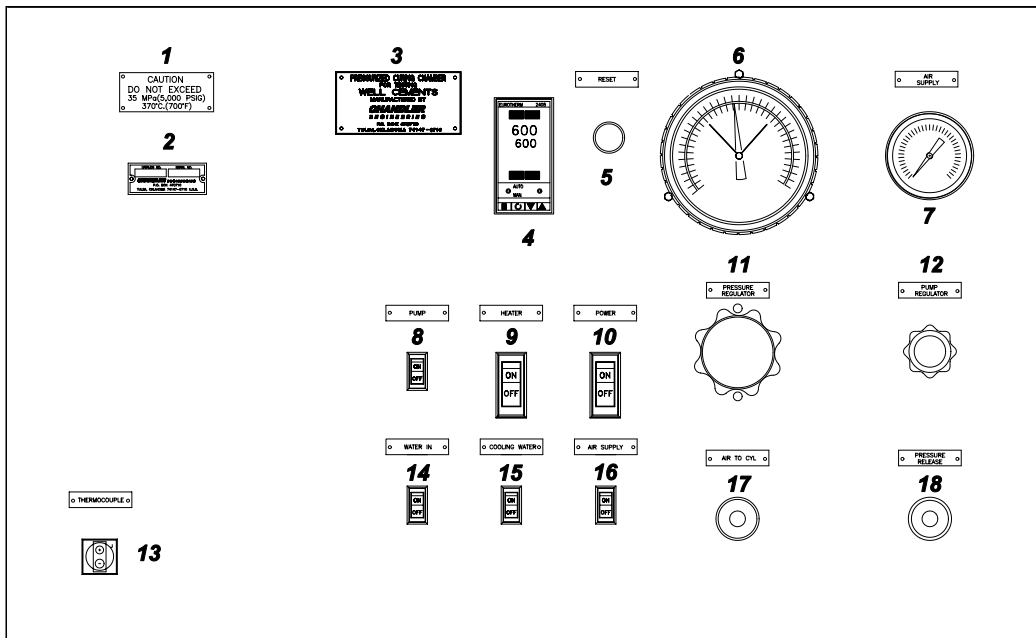

1. PRESSURE-TEMPERATURE RESTRICTION
2. SERIAL NUMBER PLATE
3. NAMEPLATE
4. TEMPERATURE CONTROLLER
5. HIGH PRESSURE/TEMP CUT-OUT RESET
6. PRESSURE GAUGE
7. AIR SUPPLY GAUGE
8. PUMP SWITCH
9. HEATER SWITCH
10. POWER SWITCH
11. HIGH PRESSURE REGULATOR
12. PUMP REGULATOR
13. THERMOCOUPLE
14. WATER IN SWITCH
15. COOLING WATER SWITCH
16. AIR SUPPLY SWITCH
17. AIR-TO-CYLINDER VALVE
18. PRESSURE RELEASE VALVE

		UNLESS OTHERWISE SPECIFIED DIMENSIONS IN INCHES [mm]	
		TOLERANCES:	
		1 PLACE	+0.030 [.76]
		2 PLACE	+0.010 [.25]
		3 PLACE	+0.005 [.127]
		ANGLES	±1/2° 32/
		SURF. FINISH	
7355	7355 CURING CHAMBER		
NEXT ASSY	USED ON		
APPLICATION		APPROVALS	DATE

CHANDLER ENGINEERING			
TITLE PANEL IDENTIFICATION MODEL 7355			
SIZE	S.O. NO.	DWG NO.	REV.
C		07-1438	C
SCALE:	N/A	DO NOT SCALE DRAWING	SHEET: 1 of 1

This document and the drawings and technical data contained hereon are the property of Chandler Engineering Company LLC. Reproduction or dissemination in any form except as expressly authorized by the owner is forbidden. The holder agrees to return this document to the owner on demand.
Copyright by Chandler Engineering Company LLC

6

5

4

3

2

1

REVISIONS				
ZONE	REV	DESCRIPTION	DATE	APPROVED
N	ECN T4504	UPDATED VIEW OF C10843	3/30/12	SB/TC
F5	P	ECN T6343; UPDATED WIRING	1/12/15	TC
R	ECN T6737	UPDATED COMPONENTS	8/31/15	TAS

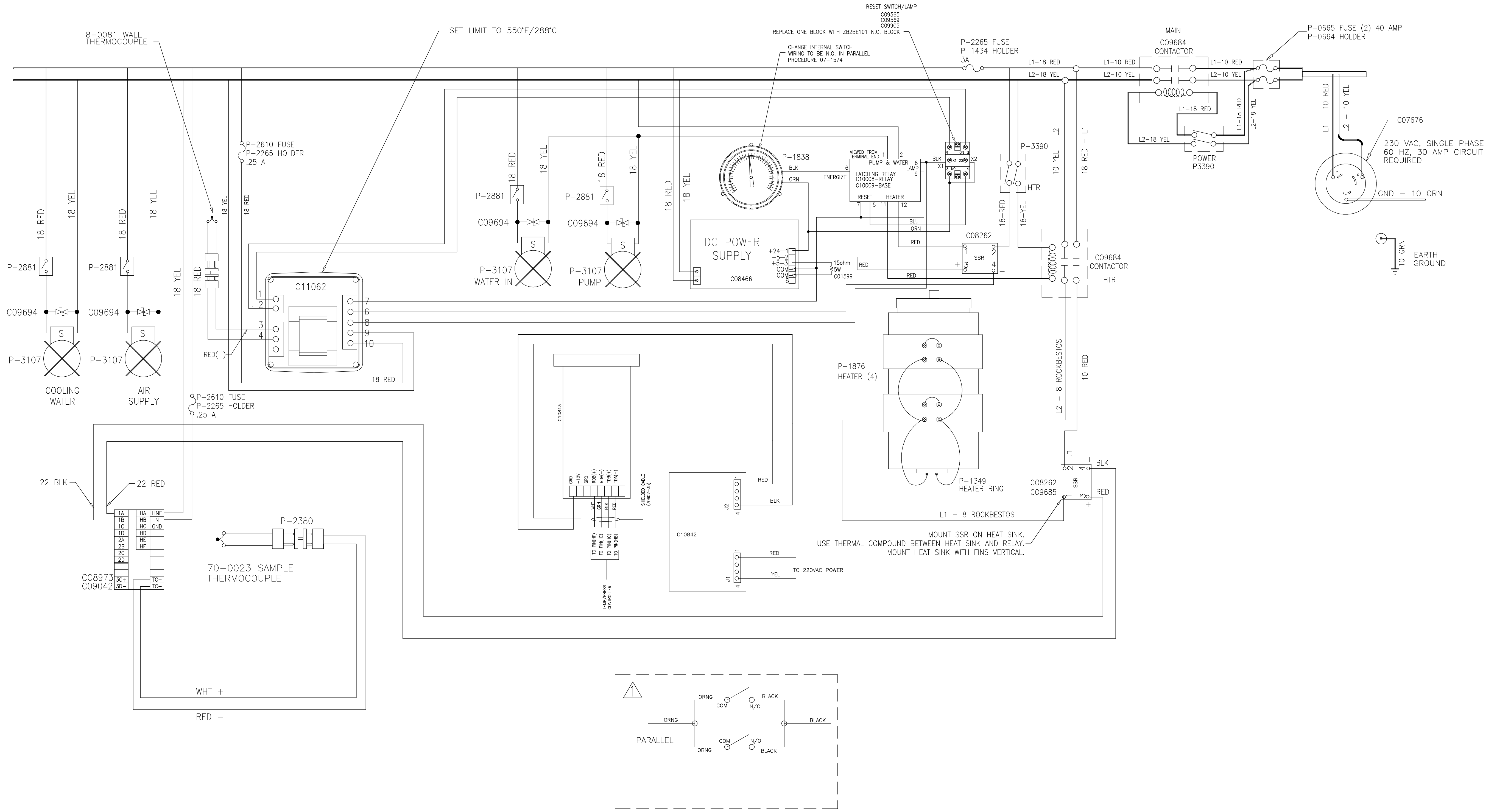

APPROVALS		DATE		SIZE	S.O. NO.	DWG NO.	REV.
DRAWN:	JJM	03/01/01					
CHECKED:	BD	02/25/02				07-1449	
ENGR.:	JJM	03/01/01					

TOLERANCES:		UNLESS OTHERWISE SPECIFIED DIMENSIONS IN INCHES [mm]	
1 PLACE	+0.030 [-.76]		
2 PLACE	+0.010 [-.25]		
3 PLACE	+0.005 [-.127]		
ANGLES	+1/2°		
SURF. FINISH	32/		

CHANDLER ENGINEERING		TITLE	
		WIRING DIAGRAM	
		MODEL 7355	

This document and the drawings and technical data contained herein are the property of Chandler Engineering Company LLC. Reproduction or dissemination in any form except as expressly authorized by the owner is forbidden. The holder agrees to return this document to the owner on demand.

Copyright © by Chandler Engineering Company LLC

12 11 10 9 8 7 6 5 4 3 2 1

H H

G G

F F

E E

D D

C C

B B

A A

12 11 10 9 8 7 6 5 4 3 2 1

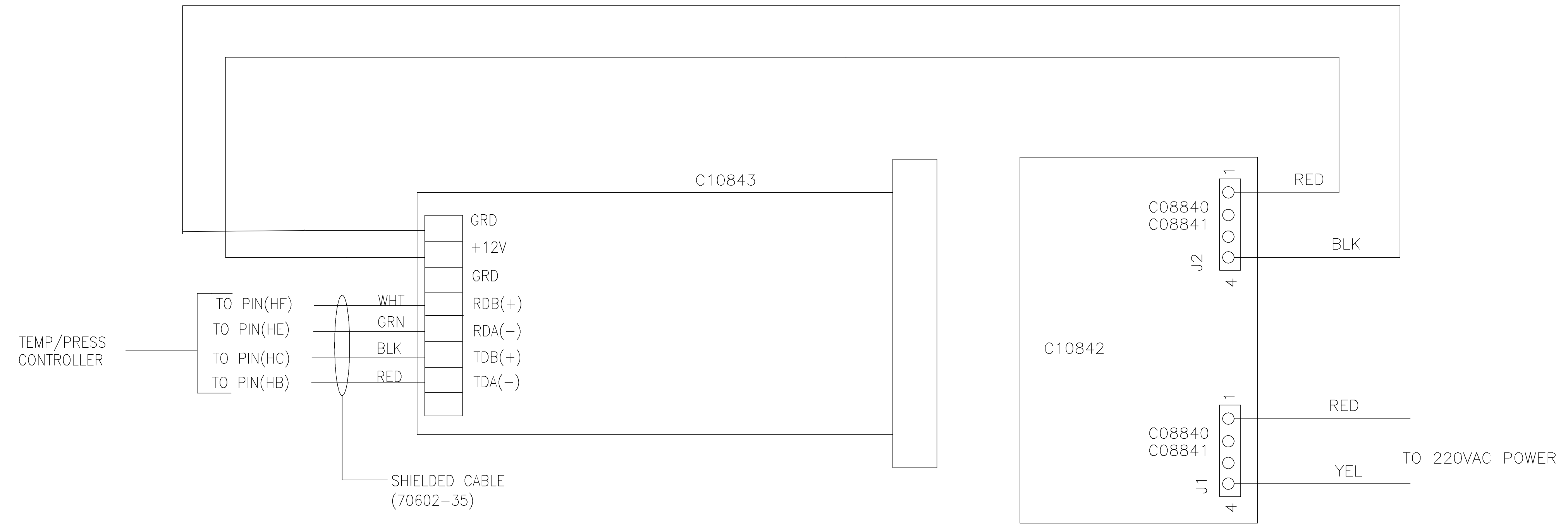

C08973-CONTROLLER
C09042-MODULE

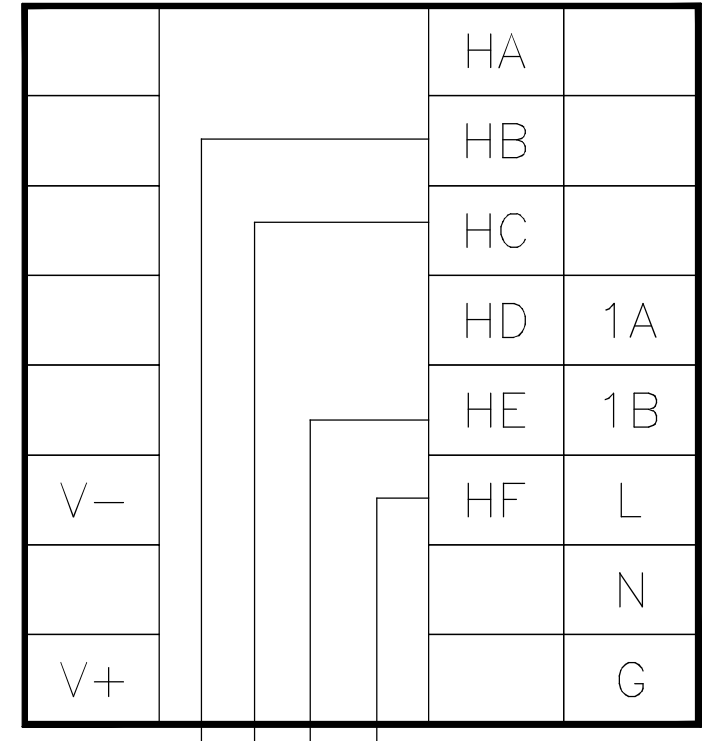

NOTE:
USE 4-COND.CABLE FOR THIS OPTION.
(70602-35)

RED TO PIN (HB) TEMP/PRESS CONT
BLACK TO PIN (HC) TEMP/PRESS CONT
GREEN TO PIN (HE) TEMP/PRESS CONT
WHITE TO PIN (HF) TEMP/PRESS CONT

5270 HARDWARE OPTION

		UNLESS OTHERWISE SPECIFIED DIMENSIONS IN INCHES [mm]		CHANDLER ENGINEERING			
HPHT RHEOMETER		TOLERANCES:		TITLE			
NEXT ASSY USED ON		1 PLACE +0.030 [.76]		WIRING DIAGRAM			
APPLICATION		2 PLACE +0.010 [.25]		MODEL 7355			
BREAK SHARP EDGES, DEBURR		3 PLACE +0.005 [.127]		DRAWN: JJM 03/01/01			
		ANGLES +1/2° 32/		SIZE D			
		SURF. FINISH		S.O. NO.			
		APPROVALS		DWG NO. 07-1449			
		DATE		REV. R			
		DRAWN: JJM 03/01/01		ENGR.: JJM 03/01/01			
		CHECKED: BD 02/25/02		SCALE: 1 = 1			
		ENGR.: JJM 03/01/01		TITLE BLOCK REV: 1.0 SHEET: 2 of 2			

REVISIONS				
ZONE	REV	DESCRIPTION OF REVISION	DATE	APPROVALS
	D	ECN 7756, ELIM REMOTE CABINET	05/03/02	BD/TC
	E	ECN 828, UPDATED BOM	5/8/07	JB/TC
	F	ECN# T3153, REPLACE P-1206 W/ 69-793	7/19/10	SS/JS

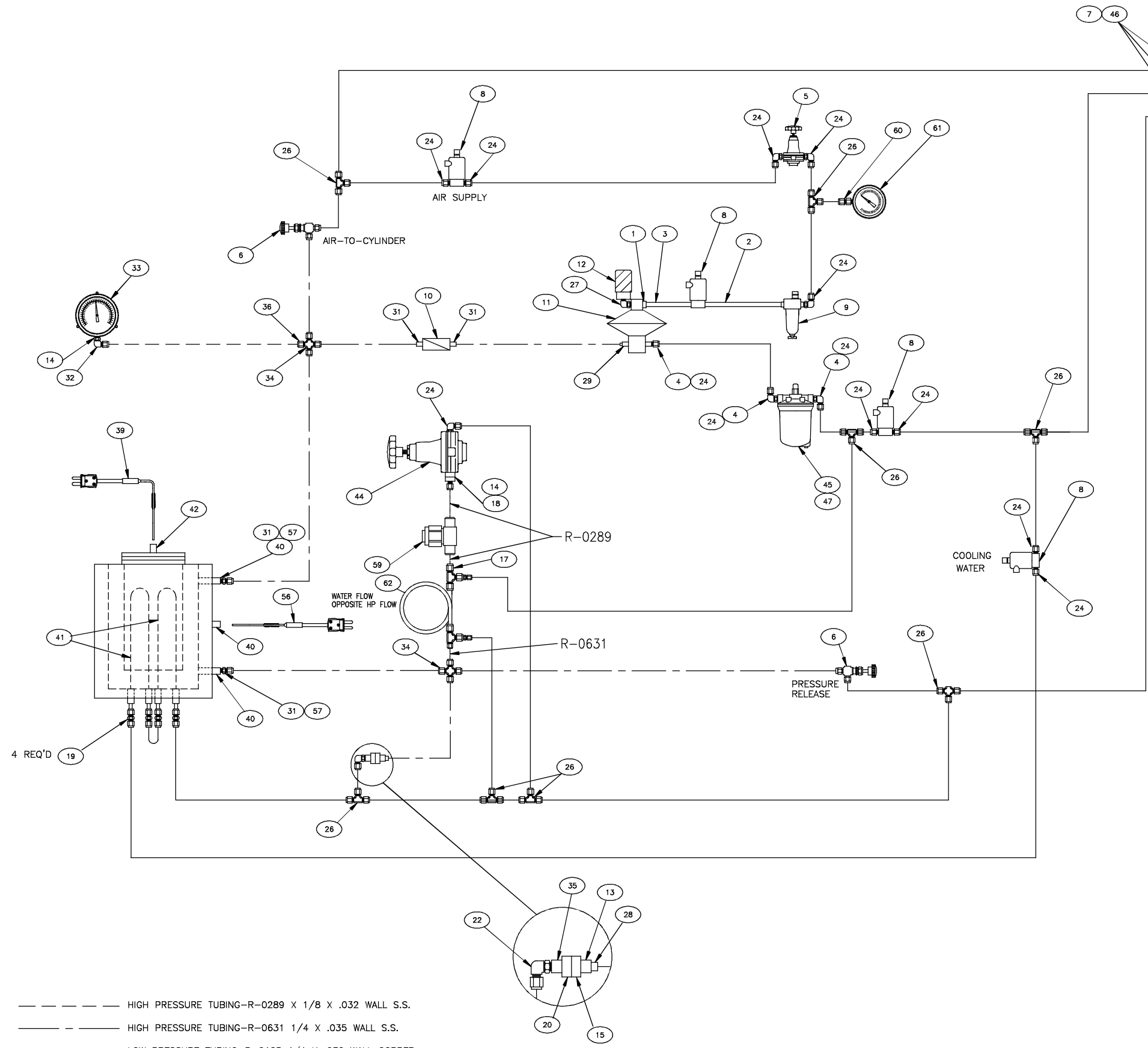

QTY.	REV.	PART NUMBER	DESCRIPTION	MATERIAL SPEC.	ITEM
		1	98-0314	ASSY, HEAT EXCHANGER	62
		1	P-1840	GAUGE, 1000 PSI/700 kPa	61
		1	P-1267	CONN., 1/4 FP X 1/4T, BRASS	60
		1	C09298	FILTER, H.P., 7 MICRON	59
					58
		2	P-1087	ADAPTER, SS, 1/4FPT x 1/4HPT	57
		1	8-0081	THERMOCOUPLE, WALL	56
					55
					54
					53
					52
					51
					50
					49
					48
		1	P-0922	BRKT, ANGLE, FILTER	47
		3	P-1954	BULKHEAD, TUBE, 1/4"T X 1/4"T	46
		1	07-0967	FILTER, OIL	45
		1	C09215	REG,BP,50-6KSI,TESCOM	44
					43
		1	07-1448	ADAPTER, CENTER THERMOCOUPLE	42
		2	07-1436	COIL, INTERNAL, COOLING	41
		3	07-1434	ADAPTER, THERMOCOUPLE	40
		1	70-0023	THERMOCOUPLE	39
					38
		1	07-1257	PLATE, MOUNTING, WATER SERVICE	37
		1	P-1944	TUBE, REDUCER, SST, .125TX.25T	36
		1	P-0269	BUSHING, REDUCING, 1/8FP X 3/8MP	35
		2	P-1941	TUBE, CROSS, SST, .25T	34
		1	P-1838	GAUGE, PRESSURE, 10000PSIG, SWITCH	33
		1	188-08984	ELBOW,SS,1/8MPX1/8T,SW	32
		4	P-1488	TUBE CONN, SS .25TX .25MP	31
		2	P-0193	GLAND, SST, TUBE, 1/4T	30
		1	P-1389	TUBE CONN, SST,.25TX.375MP	29
		1	P-1378	TUBE, CONN, SST,.25TX.125FP	28
		1	P-1285	PIPE ELBOW, STREET, BRS,.50	27
		8	P-1265	TEE,.25 TUBE SWAGELOK	26
					25
		13	P-1255	ELBOW,.25 TUBE X .25 MPT, BRS	24
					23
		1	P-1246	ELB, 1/8MNPT x 1/4T	22
					21
		1	69-793	SAFETY HEAD, .25 X .083 TBG	20
		4	P-1189	UNION,TUBE, .25 SWAGELOK	19
		1	187-20404	ELBOW,SS,1/8TX1/4MP,SW	18
		1	188-15178	CONN, 1/8MP X 1/8T	17
					16
		1	P-1880	DISK, RUPTURE, 6000 PSI, 1/4	15
		2	P-0741	SNUBBER, .25MPX.25FP	14
		1	P-0735	TUBE ADAPTER, SST,.125MPX.25T	13
		1	P-0674	MUFFLER, 1/2MPT,3.75Dx5.5L	12
		1	P-0659	PUMP, AIR/HYDRAULIC	11
		1	P-0586	VALVE, CHK, SST,.25FPX.25FP	10
		1	P-0518	LUBRICATOR, HYDR,.33PT,.25FPX.25FP	9
		4	P-3107	VALVE, SOL, .25FP,.09370RF, 240V	8
		3	C08268	RETAINER,SST,3/4ID,BHD,SW	7
		2	C09111	VALVE, NDL, SST, 1/4 T x 1/4 T	6
		1	P-0284	REGULATOR, PNL, 5-125 PSI,.25FP	5
		3	P-0866	PIPE BUSHING, BRS .375MP X 1/4FP	4
		1	P-0255	PIPE NIPPLE .25 X 3	3
		1	P-0254	NIPPLE, CLOSE, .25 NPT	2
		1	P-0256	PIPE, BSHG, BRS,.50 X .25	1

- - - - - HIGH PRESSURE TUBING-R-0289 1/8 X .032 WALL S.S.
 - - - - - HIGH PRESSURE TUBING-R-0631 1/4 X .035 WALL S.S.
 _____ LOW PRESSURE TUBING-R-0125 1/4 X .032 WALL COPPER

PARTS LIST		UNLESS OTHERWISE SPECIFIED DIMENSIONS IN INCHES [mm]		TOLERANCES:		TITLE	
1 PLACE	+0.030	[.76]	CHANDLER ENGINEERING		TUBING DIAGRAM		
2 PLACE	+0.010	[.25]			MODEL 7355		
3 PLACE	+0.005	[.127]					
ANGLES	+1/2"						
SURF. FINISH	32/						
APPROVALS	DATE	SIZE	SQ. NO.	DWG NO.	REV.		
DRAWN: JJM	03/01/01	D		07-1454	F		
CHECKED: BD	09/19/02						
ENGR.: JJM	03/01/01	SCALE: 1 = 1	TITLE BLOCK REV: 1.0	SHEET: 1 of 1			

This document and the drawings and technical data contained hereon are the property of Chandler Engineering Company LLC. Reproduction or dissemination in any form except as expressly authorized by the owner is forbidden. The holder agrees to return this document to the owner on demand.
Copyright by Chandler Engineering Company LLC

